



Wideband Fibre Transmitter

INSTRUCTION MANUAL

WFRX2-G2 | WFTX3-G1



www.whytetechnologies.com

In the interest of continuous improvement,
all specifications of products within this brochure are
subject to change without notice.

CONTENTS

Safety	3
Precautions	4
Guarantee	5
General Description	5
Product Description	6
Technical Description	7
Installation Instructions	8
Example Configurations	18
Specifications	22

SAFETY

Before installation and operation carefully read these instructions. Observe the warnings given.

These Fibre Transmitters are intended for indoor use only. Do not install the transmitters in damp, humid hot or dusty areas.

Switch off and remove the power supply when making RF or Optical connections to the transmitters to avoid damage or potential exposure to the laser light radiation.

Always Earth bond the transmitters using the Earth Bonding Lug to a suitable bonding point using 4mm² diameter earth cable.

WARNING Class 1M laser products usually produce beams with a large diameter. Therefore, only a small part of the whole laser beam can enter the eye.

However, Class 1M laser products can be harmful to the eye if the beam is viewed using magnifying optical instruments.

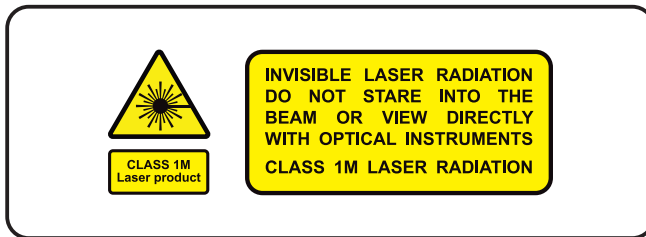

PRECAUTIONS

To ensure trouble free operation:

Do not remove the cover or disassemble the transmitter(s) as this will instantly void the guarantee and potentially expose you to invisible laser radiation.

The 75Ω Female F connectors on this unit are designed for use with '100' type coaxial cable that has a centre core diameter of 1mm2 where you are using larger core '125' or '167' coaxial cable F connectors with suitable reduction pins must be used, otherwise damage to the unit will occur which will invalidate the warranty.

Do not overtighten the F connectors (finger tight only).

The optical interfaces are SC APC (Angled Physical Contact) across the entire Whyte Technologies Series F product range. See figure 1 below. Optical connections only require insertion to where the connector clicks in place excessive force should not be used.

Figure 1

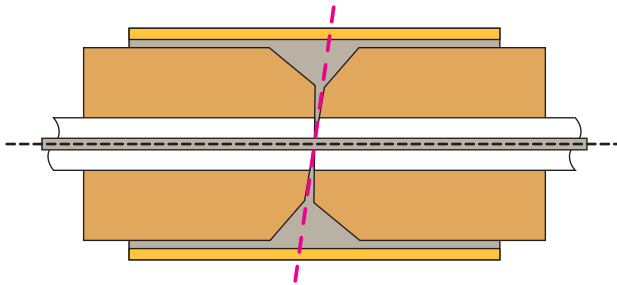

SC APC Connector (8° Angle)

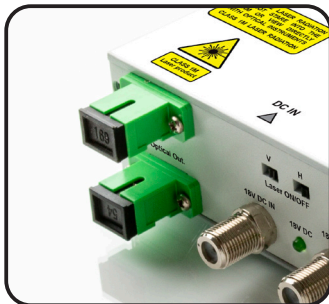

Female SC APC sockets

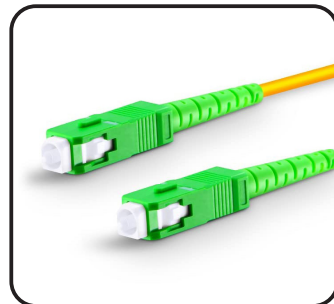

Male SC APC

GUARANTEE

All Whyte products are guaranteed for a period of 4 years from the date of purchase against defects. Within this guarantee period, Whyte Technologies will repair or replace the faulty product. In the unlikely event of a fault, please return any faulty products through your distributor.









The Guarantee will be deemed as null and void if the serial number of the product is removed, damaged or illegible. The Guarantee excludes defects caused by incorrect use, accidental damage, disassembly, water, fire, lightning damage, or a lack of ventilation.

GENERAL DESCRIPTION

The Whyte WFTX range of Optical Fibre Transmitters offer an efficient quality solution for Fibre IRS Systems. Designed to provide the ultimate in low signal degradation Fibre IRS Systems, Whyte Optical Transmitters utilise a single laser per input which are combined on to a single optical output.

The V and H SAT inputs are compatible with all Wideband LNB's (Quattro via 2 transmitters) and will accept any signals within the 290~2340MHz range. The TERR input 47 ~ 862MHz supports FM, DAB and DTT.

Features include:

-  4 Year Warranty
-  Wideband SAT Input
-  Full band TERR Input
-  Variable Slope Control
-  RF and Laser Indicators
-  Multiple mounting options
-  Satellite and TERR Optical Transmitter
-  Single laser per input minimal signal degradation
-  9dBm Optical Power supporting 32-Way split
(64-way split possible with equalised SAT transponders)

PRODUCT DESCRIPTION

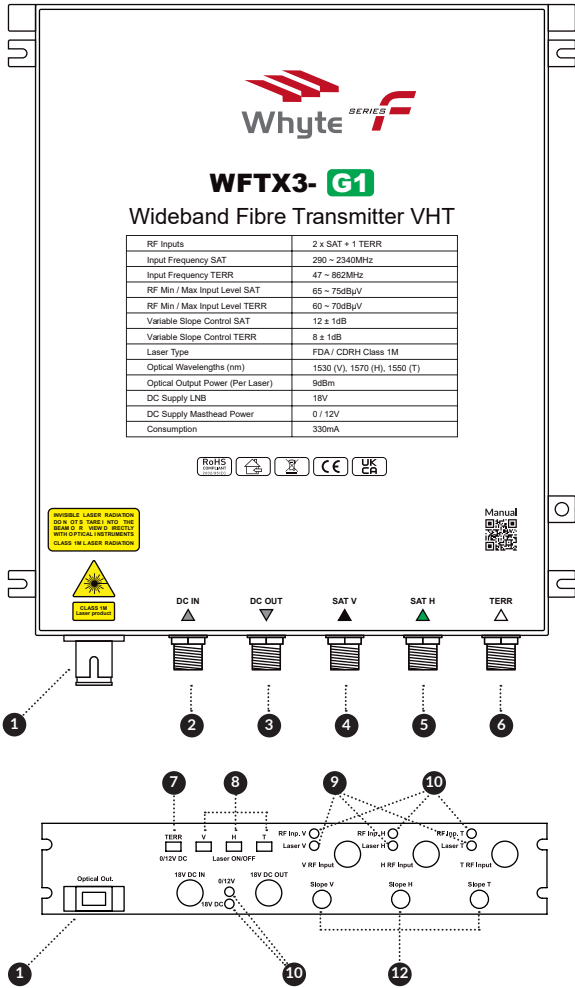

- | | |
|-----------------------------|-----------------------------|
| 1. Fibre Optic Connector(s) | 7. TERR DC 0/12V DC |
| 2. DC Input (18V DC) | 8. V H and T Laser ON/OFF |
| 3. DC Output | 9. Laser Indicators |
| 4. SAT V RF Input | 10. RF Indicators |
| 5. SAT H RF Input | 11. DC Indicators |
| 6. TERR RF Input | 12. Slope Control V H and T |

Model WRTX3-G1 shown for illustrative purpose only

TECHNICAL DESCRIPTION

The WFTX3-G1 is a Wideband SAT and TERR RF over fibre optic transmitter designed for use in Whyte RF Over Fibre IRS equipment (FIRS). The WFTX3-G1 Features: Three Laser modules, SC APC Optical output, Vertical, Horizontal and Terrestrial RF Inputs, DC in and DC Output, Laser On/Off switches for V, H & TERR, Variable Slope Control for V, H and TERR and Masthead Power switch for enabling/disabling 12V DC at the TERR RF input. This is a three-laser CWDM device.

The WFTX2-G2 is a Wideband SAT only over fibre optic transmitter module designed for use in Whyte RF Over Fibre IRS systems. The WFTX2-G2 Features: Two Laser modules, SC APC Optical Input, SC APC Optical Output, Vertical and Horizontal RF Input, DC in and DC Output, Laser On/Off switches (V & H) and Variable Slope Control (V and H). This is a two-laser CWDM device featuring an optical loop-through so that the WFTX3-G1 and WFTX2-G2 can be linked together enabling two satellites (Wideband) and terrestrial to be sent over one fibre using five laser frequencies or one Quattro SAT + TERR (also over a single fibre).

LASER GROUPS

For the convenience of installation Whyte fibre products are grouped so that it is easy to match up your devices.

Group 1 (green identifier G1) laser products utilise the following laser frequencies:

1530nm SAT 1 VERTICAL (or Quattro VL)

1550nm TERR

1570nm SAT 1 HORIZONTAL (or HL)

Group 2 (purple identifier G2) laser products utilise the following laser frequencies:

1510nm SAT 2 VERTICAL (or Quattro VH)

1590nm SAT 2 HORIZONTAL (or Quattro HH)

INSTALLATION INSTRUCTIONS

Select a suitable location to install the fibre transmitter(s). Do not install the fibre transmitter(s) in damp, humid, hot, or dusty areas. Using the screw slots on the moulded corner brackets, secure the transmitter using the appropriate fixing screws and wall plugs to suit the relevant wall surface or cabinet. See Figure 2.

Figure 2

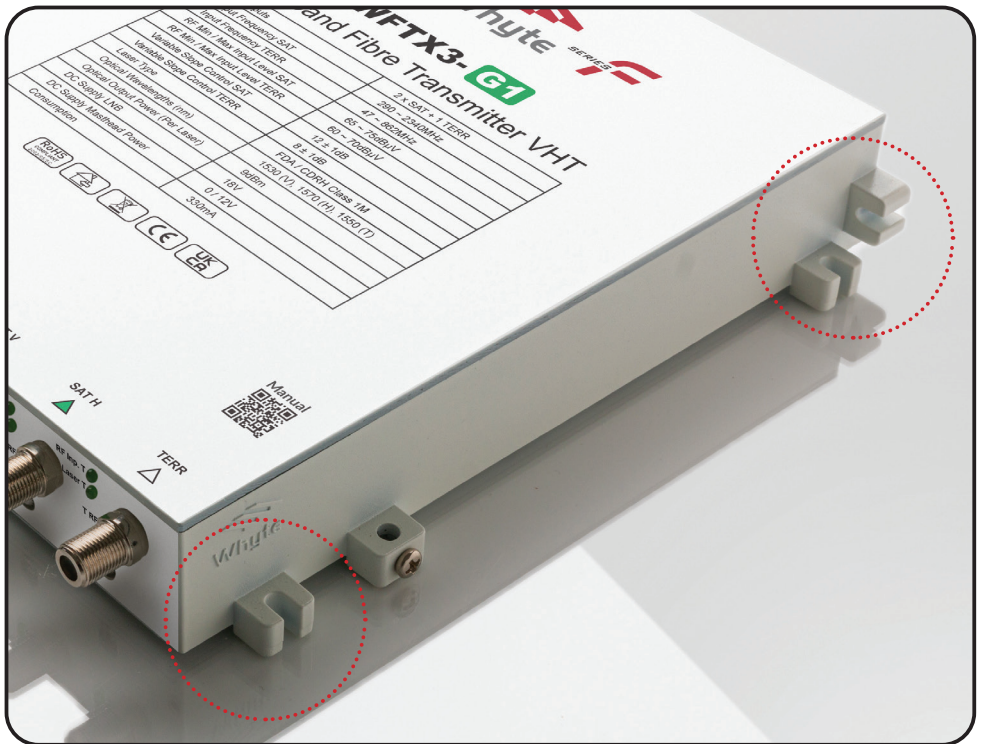

The screw fixing points allow for various mounting orientations.

Please note:

These transmitters weigh 1.4kg (just over 3 lbs) please ensure your fixings are secure. 19" 1U and 4U Rack mount options are available, contact your local Whyte distributor for further information.

Connecting the Subscriber Cables

Ensure that all drop cables have drip loops prior to their entering the building. Connect the SAT and TERR drop cables to the corresponding Satellite & TERR Inputs of the transmitter.

The diagram below shows an ideal F-Type coaxial connector configuration.

Figure 3

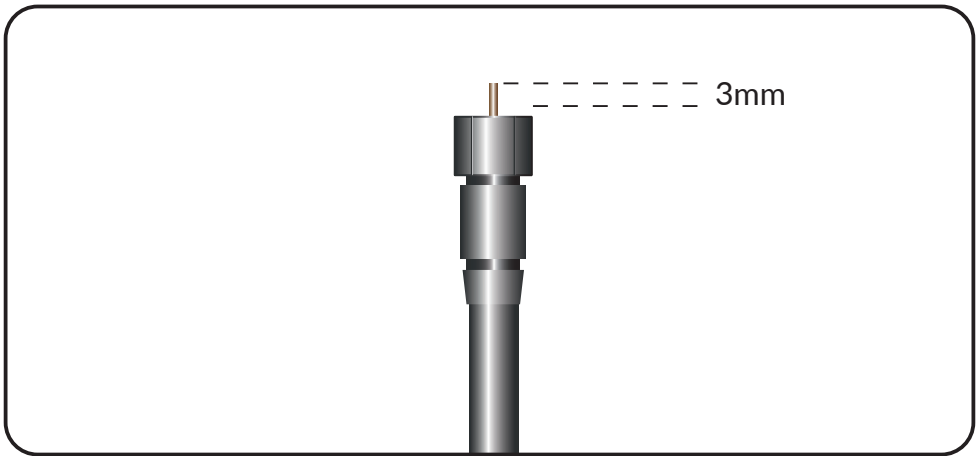

Ideal centre core conductor length relative to the nut edge

If a sleeved multi core coaxial cable has been used for your incoming feeds, ensure that the outer jacket is not facing upwards and cannot collect rainwater.

Ensure your Satellite Dish and Terrestrial Antenna provides adequate signal levels from the satellite and terrestrial transmitter being received. Keep in mind that there will be signal losses within coaxial cable and the introduction of slope over distance. Ensure that the satellite drop cables are connected correctly in the corresponding order with respect to the LNB output and the transmitter(s) SAT inputs. For Terrestrial if an external masthead amplifier has been used a selectable 12V DC supply is available at the TERR RF input.

Optical Connections

The SC APC optical Output (and Input on the WFTX2-G2) comes pre-fitted with a protective dust cap. As with all optical connections ensure that the surfaces are clean and free from contamination before making the connection. See figure 4.

Please note:

Safe practices when working with lasers should always be observed!

Figure 4



SC APC Female Connectors

Figure 5

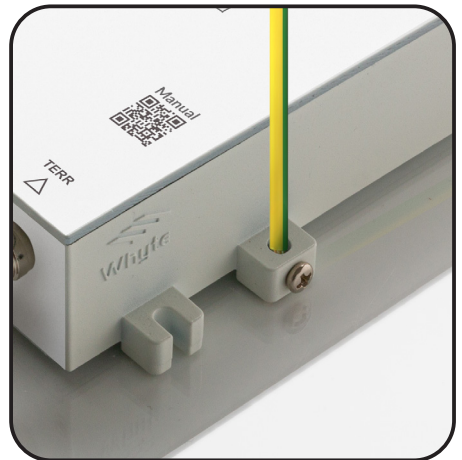

The Earth bonding is secured by the side mounted screw shown.

Earth Bonding

Earth bond the transmitter(s) to the Earth Bonding Lug and using minimum 4mm² Earth Bonding Cable. It is best practise to earth bond across all devices using a single unbroken Earth Bonding Wire.

Make sure that the Earth Bonding Cable is connected directly to the building's PME (Protecting Multiple Earthing). See figure 5.

OPTOMISING SYSTEM PERFORMANCE

System performance is optimised at the **RF Input** levels of:

65 ~ 75dB μ V SAT Max. Transponder level per path
60 ~ 70dB μ V TERR Max. Mux level

Once the ideal RF input levels have been established the process of slope correction can take place. At input levels outside those recommended above the performance may be adversely affected. Ensure that your inputs are within these parameters for best performance.

For the slope correction process, you will need a Whyte Fibre receiver that matches your transmitter group and a spectrum analyser. The Variable Slope Control (VSC) is utilised to produce the flattest possible response in all instances for each path. By optimising the RF input levels and applying corrective slope adjustment the best results can be achieved across the whole system.

SAT SLOPE ADJUSTMENT

To optimise the SAT performance of your Fibre IRS System a SAT equaliser could be considered. To optimise the input for the flattest response the Variable Slope Control (VSC) will enable you counteract the slope that occurs over the coaxial cable from the LNB to the RF input of the transmitter. Ideally this would be adjusted using a Whyte fibre receiver with an appropriate optical attenuator (10dB/15dB) so that the receiver output is monitored while making the slope adjustment.

This would require the use of an appropriate 'wideband' capable spectrum analyser so that the active path may be monitored. Your analyser would need to provide the 18V to power the receiver via its wideband SAT output.

Please note:

The Variable Slope Control is easy to adjust with a flat screwdriver and has a smooth operation with end stops, please note that excessive force may result in damaging the transmitter.

Figure 6 shows the analyser is used to provide the 18V DC to the WFRXVHT-G1 receiver which enables the satellite signals to be passed to the analyser. If required, the Aux DC output of the Transmitter can be used as a local DC supply for the receiver (powering the adjacent SAT output).

Please note:

In a dual transmitter scenario, the additional WFRXVH-G2 receiver will be required for monitoring those signal paths during the slope correction process.

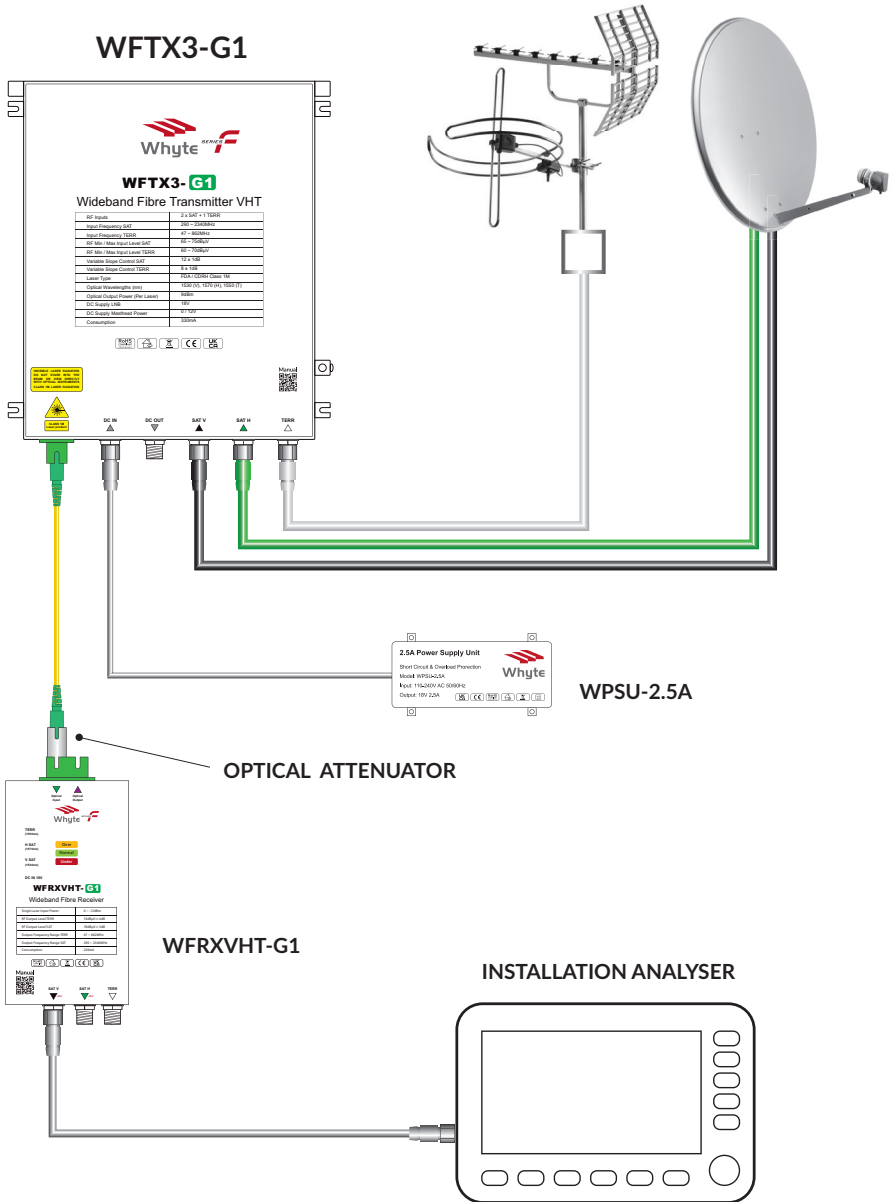

Figure 6

TERR SLOPE ADJUSTMENT

To optimise the TERR performance of your Fibre IRS System an a Terrestrial Equaliser should be considered. To optimise the input for the flattest response the variable slope control (VSC) will enable you counteract the slope that occurs over the coaxial cable from the LNB to the RF input of the Transmitter.

Ideally this would be adjusted using a WFRXVHT-G1 Whyte fibre receiver with an appropriate optical attenuator (10/15dB) so that the receiver output is monitored. Here you can power the receiver via one of the SAT outputs with an 18V supply while measuring the TERR output.

Here we are using the Aux DC output of the transmitter to provide power to one of the unused SAT outputs of the receiver enabling us to measure and adjust the output of the TERR path. The receiver shown (WFRXVHT-G1) can only be powered via the SAT outputs. See figure 7.

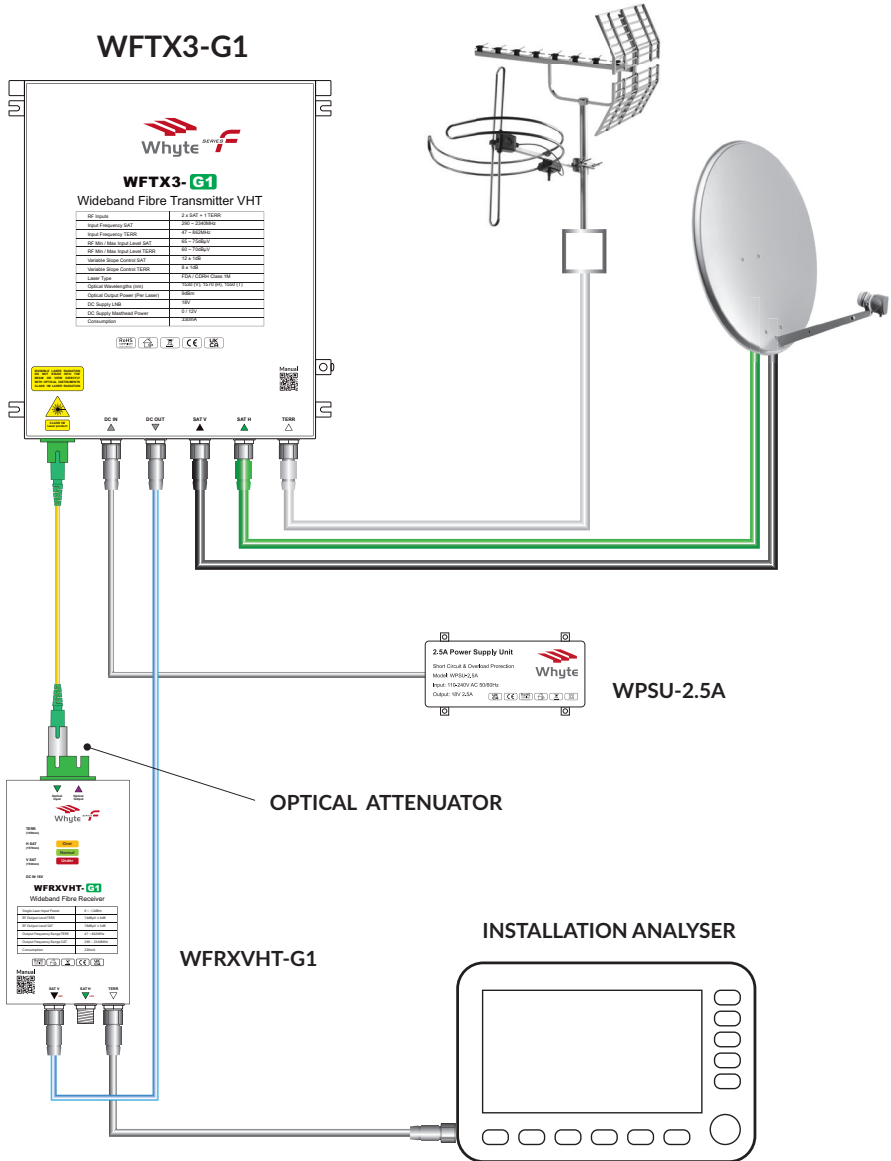

Figure 7

DUAL WIDEBAND SAT FIRS

Dual wideband satellite can be supported using two transmitters G1 and G2 and 2 matching receivers also G1 and G2. Whyte dSCRs support dual wideband input when the input switch is set to wideband providing 2 satellite paths at the REC outputs via DiSEqC switching on the receiver.

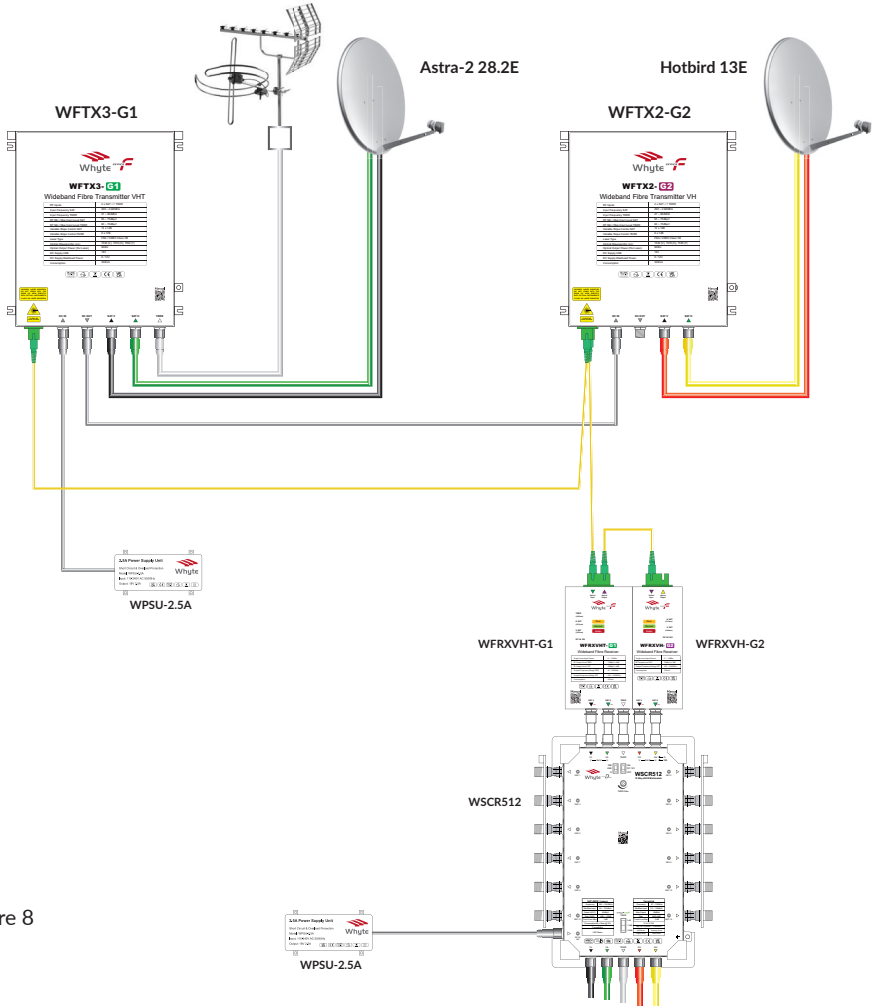

Figure 8

By linking transmitters and receivers together a single fibre will carry four satellite paths and one terrestrial path with a dedicated wavelengths per path ensuring the best possible signal quality. See figure 8

QUATTRO FIRS

In instances where a Quattro LNB source is required Transmitters are used in pairs via the optical loop in / loop out connectivity. Here each individual path is also supported by Variable Slope Control (VSC) and can be adjusted to present the flattest output for your Fibre IRS system. See figure 9.

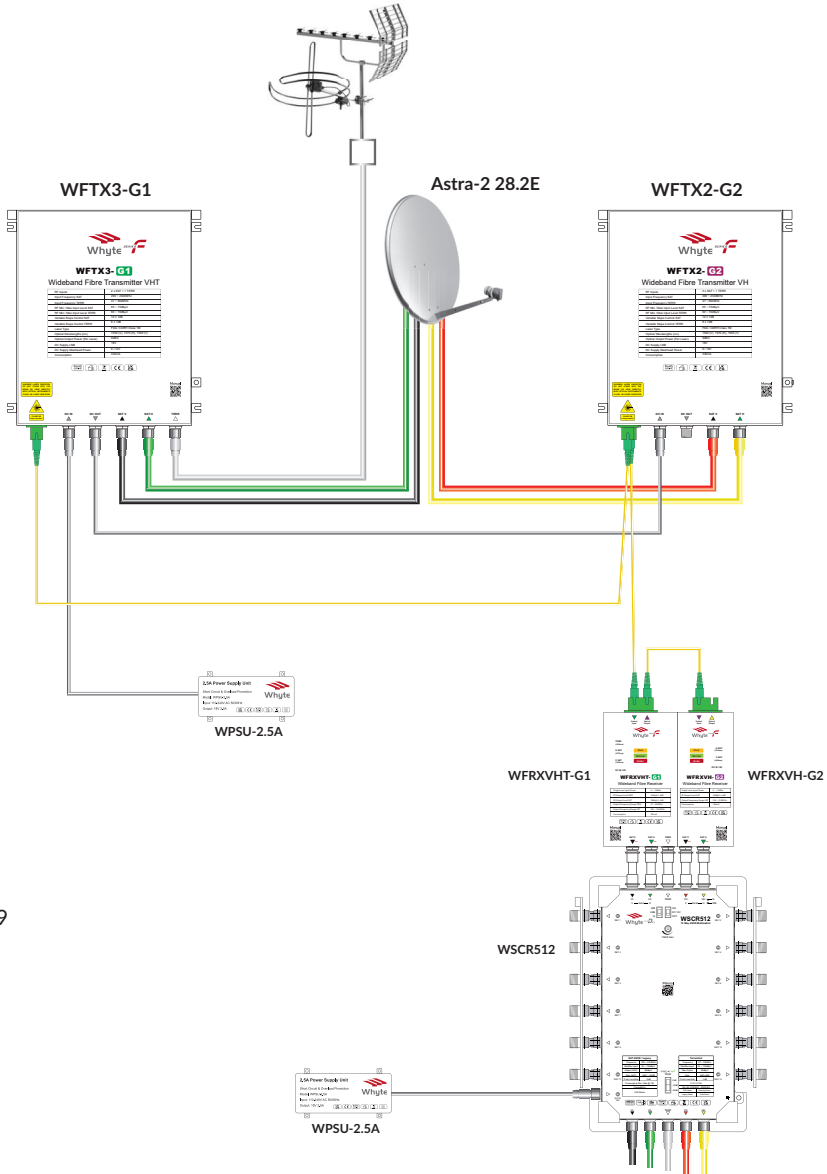
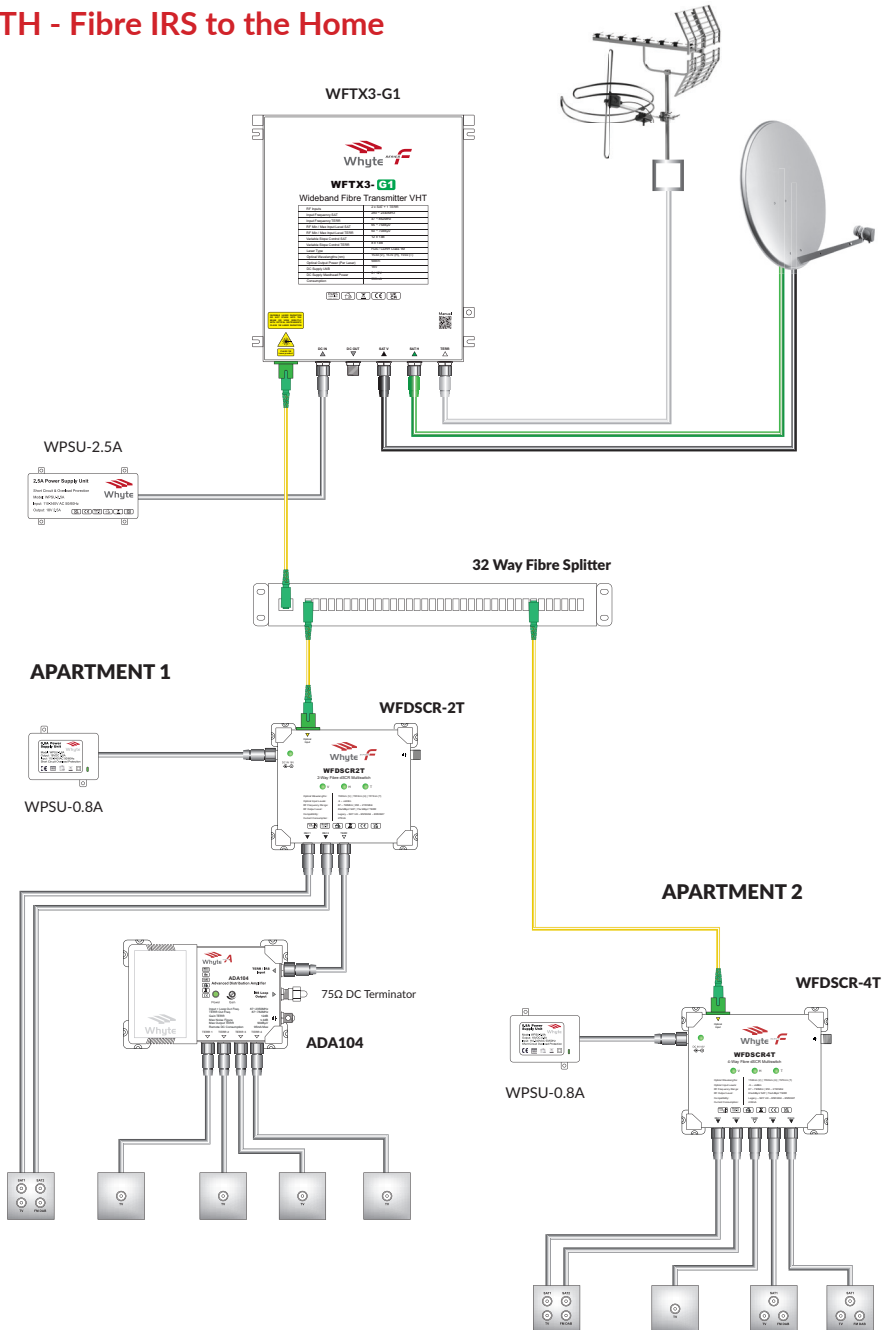

Figure 9

EXAMPLE CONFIGURATIONS

FTTH - Fibre IRS to the Home



EXAMPLE CONFIGURATIONS

FTTH - Hybrid Fibre IRS

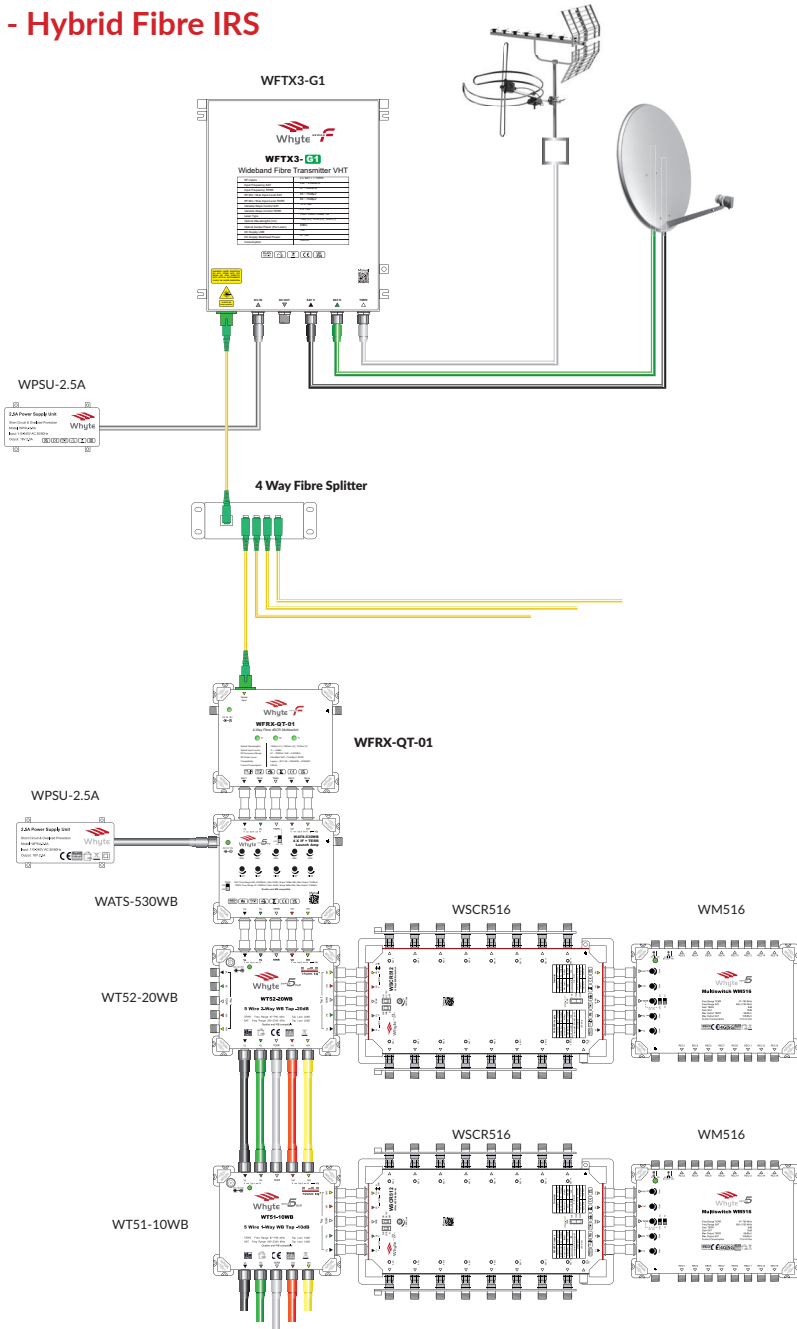

EXAMPLE CONFIGURATIONS

FTTH - Dual SAT + TERR Fibre IRS to the block

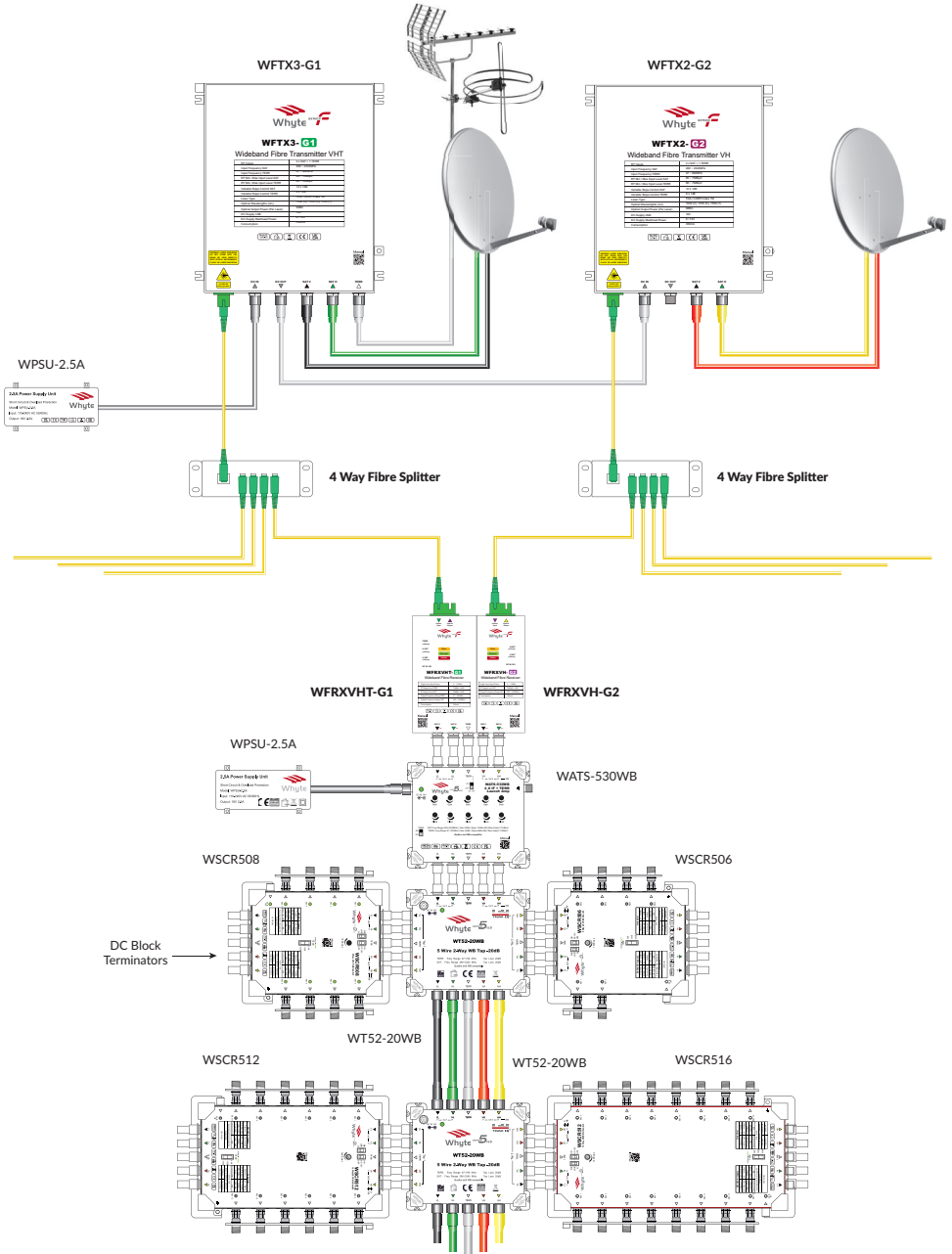

EXAMPLE CONFIGURATIONS

FTTH - Hybrid Quattro IRS

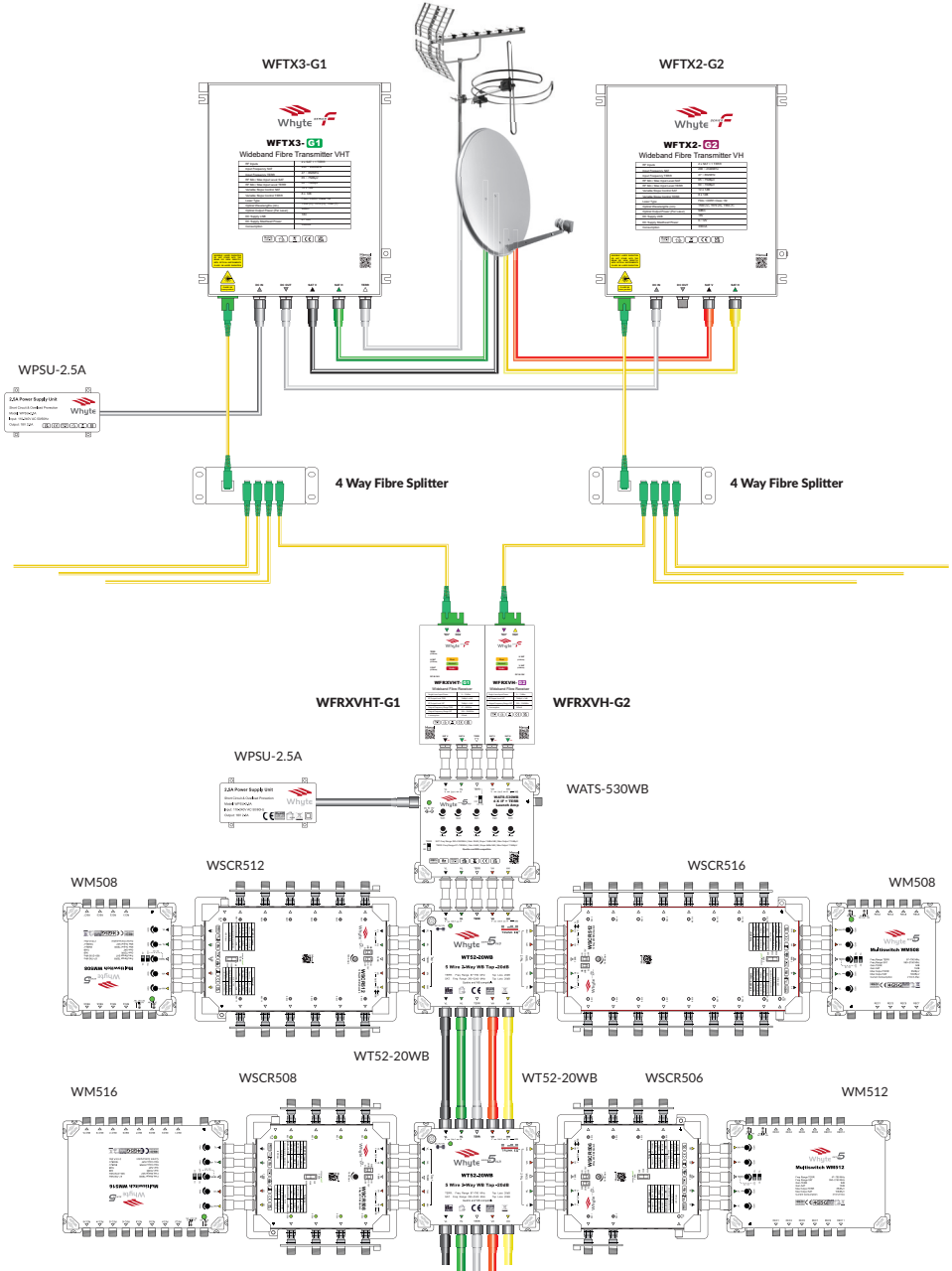

SPECIFICATIONS

Model	WRFX3-G1
RF Inputs	2x SAT + 1 TERR / 75Ω Female F-Type
Input Frequencies SAT	290 ~ 2340MHz
Input Frequencies TERR	47 ~ 862MHz
RF Input Sequence	V, H, T (left to right)
RF Min/Max Input Level SAT	60 ~ 80dBμV
RF Min/Max Input Level TERR	55 ~ 75dBμV
SAT Input Return Loss	>10dB
TERR Input Return Loss	>8dB
Variable Slope Control SAT	0 (Flat) to 12 ±1dB
Variable Slope Control TERR	0 to 8 ±1dB
RF Input Isolation	>30dB (port to port)
RF Input Status	Below Min Input LED = Off
Laser type	FDA/CDRH Class 1M
Optical Output (SC APC)	1
Optical Wavelengths	1530nm (V), 1570nm (H), 1550nm (T)
Optical Output Power (Per Laser)	9dBm
Optical Output On/Off	Switch (per laser)
Optical Output Status	LED (per laser)
DC Supply LNB H & V	18V DC
DC Supply Masthead Power MHP	12V DC (switchable)
DC Input	18V DC
DC Indicator	LED On / Off
DC Output (Aux)	18V rated to 2.5A
Consumption	330mA
Operating Temperature Range	-10 to 50°C

The EU Declaration of Conformity can be viewed at www.whytetechnologies.com.
 In the interest of continuous improvement, all specifications of products are subject to change without notice.

SPECIFICATIONS

Model	WRFX2-G2
RF Inputs	2x SAT + 1 TERR / 75Ω Female F-Type
Input Frequencies SAT	290 ~ 2340MHz
RF Input Sequence	V, H (left to right)
RF Min/Max Input Level SAT	60 ~ 80dBμV
SAT Input Return Loss	>10dB
Variable Slope Control SAT	0 (Flat) to 12 ±1dB
RF Input Isolation	>30dB (port to port)
RF Input Status	Below Min Input LED = Off
Laser type	FDA/CDRH Class 1M
Optical Input (SC APC)	1 For optical input from WFTX3-G1
Optical Output (SC APC)	1
Optical Wavelengths	1490nm (V), 1510nm (H)
Optical Output Power (Per Laser)	9dBm
Optical Output On/Off	Switch (per laser)
Optical Output Status	LED (per laser)
DC Supply LNB H & V	18V DC
DC Input	18V DC
DC Indicator	LED On / Off
DC Output (Aux)	18V rated to 2.5A
Consumption	240mA
Operating Temperature Range	-10 to 50°C

The EU Declaration of Conformity can be viewed at www.whytetechnologies.com.
 In the interest of continuous improvement, all specifications of products are subject to change without notice.



Unit 1, Watermill Business Centre, Edison Road, Enfield, EN3 7XF

Tel: 0330 999 1980 | info@whytetechnologies.com | www.whytetechnologies.com

